

# ASSEMBLY INSTRUCTIONS FOR FABRIC SUNSHADE (BIMINI)

**IMPORTANT:**  
 THIS PRODUCT DOES NOT PROVIDE FALLING OBJECT PROTECTION



**! TRANSPORTING:**

- ▲ When transporting the tractor, make sure the Fabric Sunshade is removed to prevent any damage.

**ESSENTIAL TOOLS REQUIRED:**  
 1/2" wrench (or adjustable)  
 Tape measure

**! TO AVOID PERSONAL INJURY:**

- ▲ Position the tractor on level ground
- ▲ Apply parking brake
- ▲ Shut off engine
- ▲ Remove key

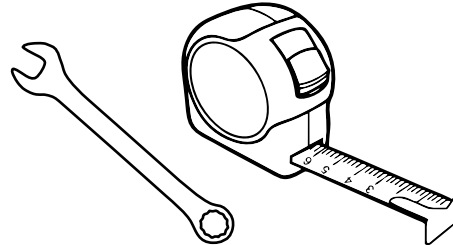

## STEP 1 UNPACKING CONTENTS:

Take all contents out of box, unwrap your new Bimini and remove all fasteners from packaging.

**PARTS LIST**



**CARE AND MAINTENANCE:**  
 Wash with mild soap, rinse thoroughly, and let dry.

Cover My Tractor, LLC  
 3145 E Chandler Blvd. Ste. 110-401  
 Phoenix, AZ 85048  
 Phone: (904) 316-0532  
 www.covermytractor.com

## STEP 2 ATTACHING THE FLAT PLATES:

On each side of the Roll Bar install the flat plates (Part #C) level to the ground, with notches facing down and rearward. Position the plates just below where the radius ends on the outer side posts of the ROPS (Roll Over Protection System). Insert the U-bolts (Part #F) with the long leg facing rearward through the slot and hole of the Flat Plate (Part #C) per Diagram 1. Fasten in place using Flat Washer (Part #B) and Flange nuts (Part #E) so that the right side of plate and left side of plate are level to each other.

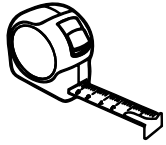

Measure right and left sides of Flat Plate, down from top of the ROPS to top of plate, to ensure plates are level.

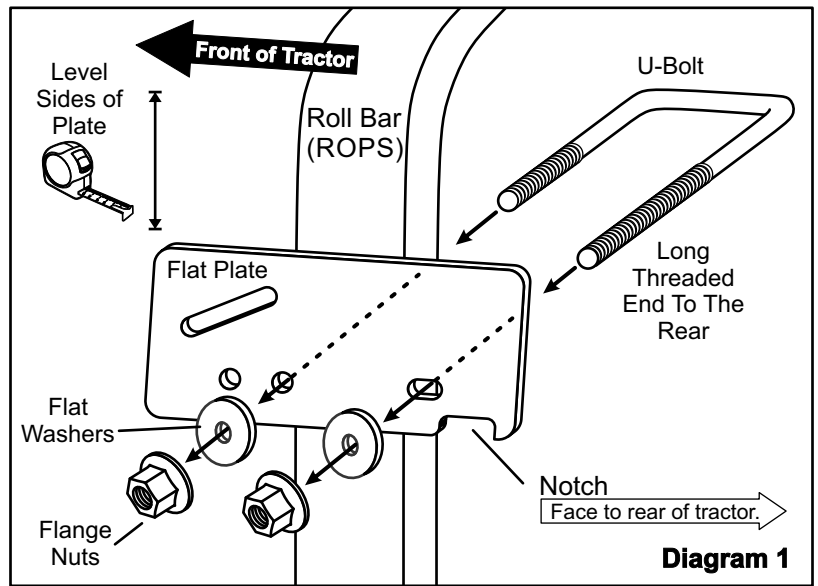

Diagram 1

## STEP 3 ATTACHING THE SUNSHADE:

Slide eye end of Bimini (Part #A) onto each long end of U-bolts (Part #F). Using the Wing Nut (Part #H) tighten until you see a few threads of U-bolt (Part #F) sticking out of the end of the Wing Nuts. DO NOT over tighten the Bimini. See Diagram 2.

Install Coupling Nut (Part #D), facing outboard, with the Thumb Screw (Part #G) through the Flat Washers (Part #B) and through the Flat Plate Slot as shown in Diagram 2.

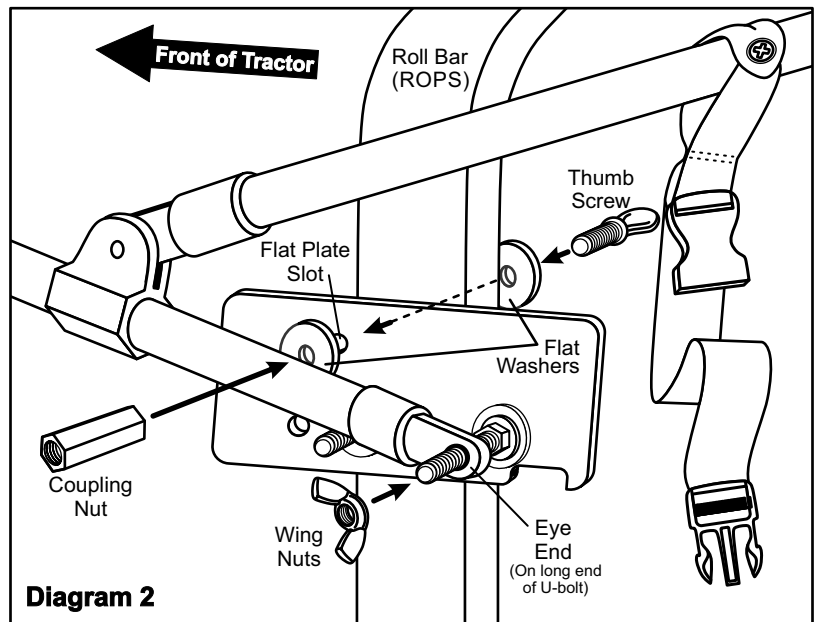

Diagram 2

## STEP 4 STRAP AND ADJUSTMENTS:

Unclip the Strap and wrap it around bottom notch of Flat Plate (Part #C) and re-clip the Strap back together. Bimini should rest up against the Coupling Nut (Part #D) as shown in Diagram 3.

Adjust the Flat Plate levelness, Coupling Nut position in slot to obtain the desired angular position. Pull down on the webbing of the strap to tighten the fabric. Reference Diagram 3.

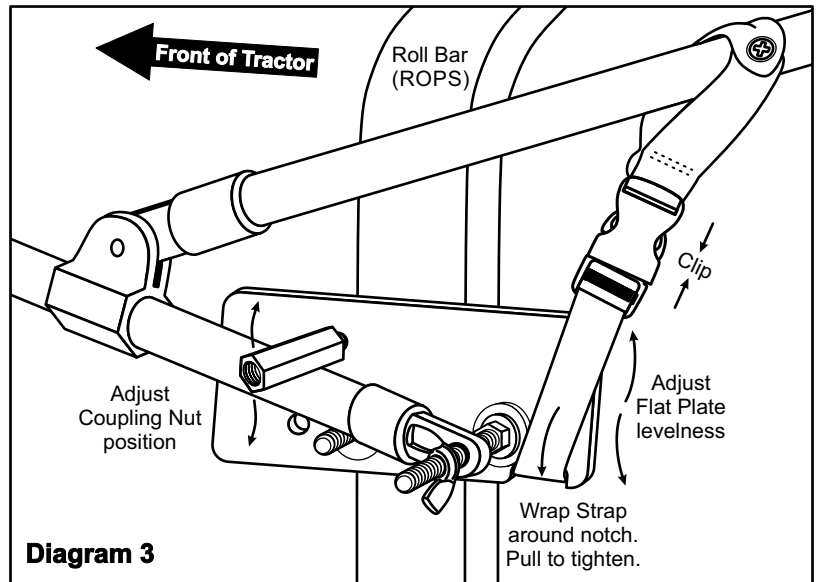

Diagram 3

Enjoy your sunshade and if you have any questions, comments, or concerns, please do not hesitate to contact our customer service at (904) 316-0532 or (904) 334-2206.

[www.covermytractor.com](http://www.covermytractor.com)